



TR82

MAIN FEATURES

- Switch Capacity up to 25A, 40A continuous current capacity.
- 4.8mm and 6.3mm flat terminals.
- Medium duty.
- Micro size plug-in design, PCB termination available.



APPLICATIONS

- Used on air conditioner, electrical heater Remote-controlled TV, automatic control and household electric device.

ORDERING INFORMATION

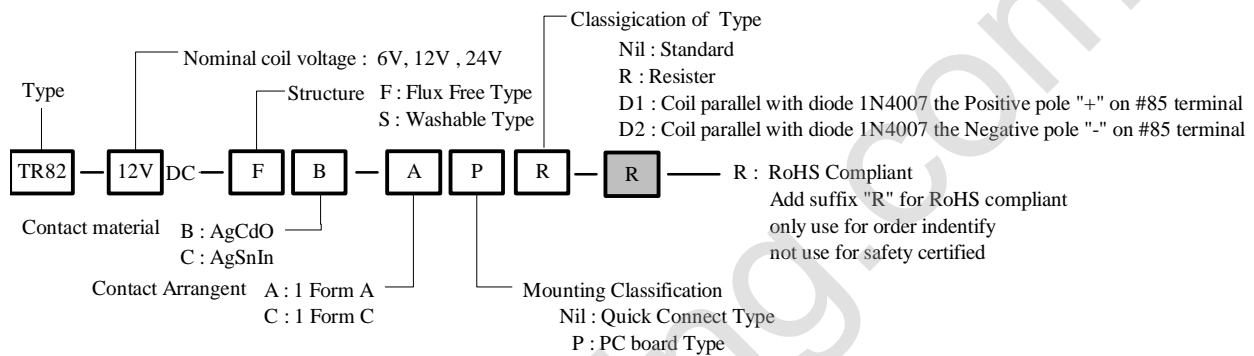

DIMENSION (unit:mm)

DRILLING (unit:mm)

WIRING DIAGRAM

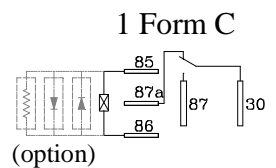
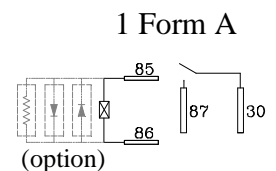
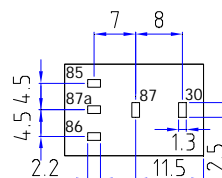
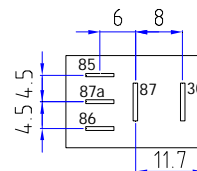
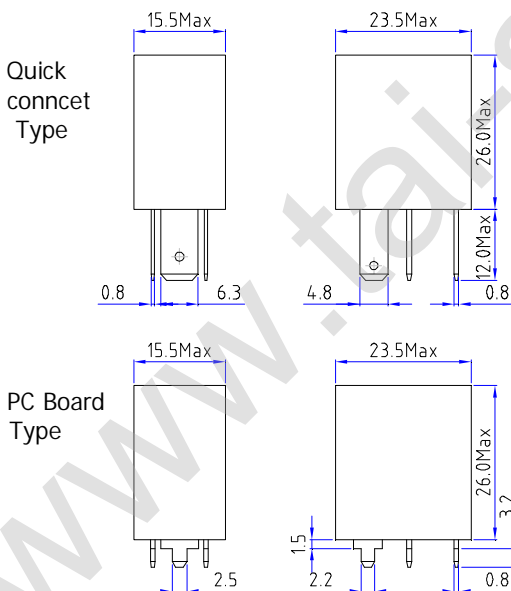

➤ **COIL DATA CHART**(at 20°C)

Contact Arrangement		Nominal Coil Voltage (VDC)	Coil Resistance (Ω) ±10%	Nominal Current (mA)	Power Consumption (W)	Pull-In Voltage (VDC)	Drop-Out Voltage (VDC)	Allowable Voltage Max (VDC)	Ralleled Resistor(Ω) (Optional)	
TR82	Form A	6	32	187.5	abt. 1.6	3.6	0.6	10.4	170	
	Form C		25	240.0				9.2		
	Form A	12	123	97.6		7.2	1.2	20.4		680
	Form C		97	123.7				18.1		
Form A	24	483	49.7	14.3	2.4	40.4	2720			
Form C		384	62.5			36.0				

➤ **CONTACT RATING**

Item	Type	TR82	
	1 Form A	1 Form C	
		N/O	N/C
Contact Capacity Resistive Load cosΦ=1	30A 14VDC	30A 14VDC	15A 14VDC
Max. Carrying Current	40A	40A	30A
Max. Make Current	90A	90A	20A
Max. Break Current	30A	30A	15A
Max. Allowable Power Force	420W		
Max. Switching Voltage	16VDC		
Contact Material	Silver Alloy		

➤ **PERFORMANCE** (at initial value)

Item	Type	TR82
Contact Resistance		100mΩ Max.
Operation Time		10msec Max.
Release Time		7msec Max.
Dielectric Strength	Between open contact Between contacts	1000VAC 50/60Hz (1 minute) 500VAC 50/60Hz (1 minute)
Surge Resistiveness		1500V
Insulation Resistance		100 MΩ Min. (500VDC)
Operating Ambient Temperature		-40°C to +85°C(No water condensation and no water drop)
Operating Humidity		45% to 85% RH
Coil Temperature Rise		40 deg. Max. (at rated coil voltage)
Vibration	Endurance Error Operation	Approx. 44.1 m/s ² (4.5G), 10 to 500 Hz Approx. 44.1 m/s ² (4.5G), 10 to 2,000 Hz
Shock	Endurance Error Operation	100G Min. 10G Min.
Life Expectancy	Mechanically Electrically	1 × 10 ⁵ operations. Min. (no load) 1 × 10 ⁵ operations. Min.
Weight		abt. 18.5grs.

➤ **REFERENCE DATA**

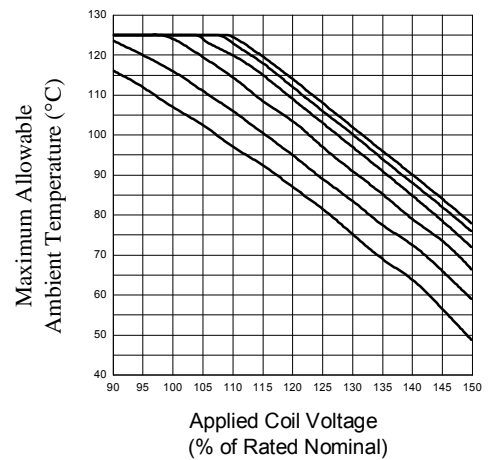
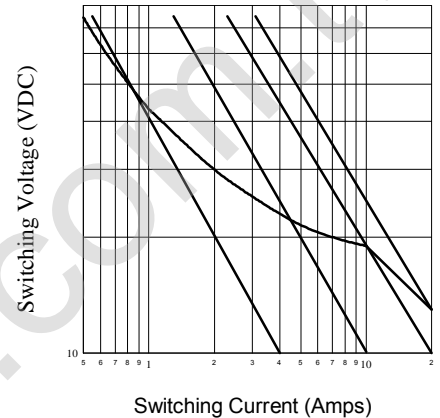

This datasheet for reference and subject to change without notice. Please double check final specification with Tai-Shing. (0939AA08VOL01)