

備註：
 1. 本圖為通電狀態 (Shown energized).
 2. 本料件符合ROHS (ROHS Compliant).

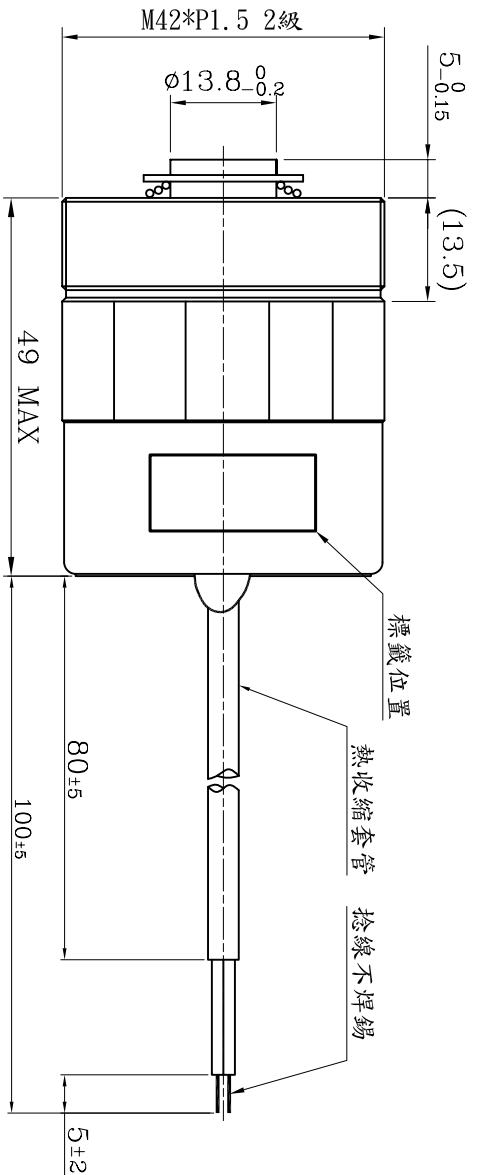
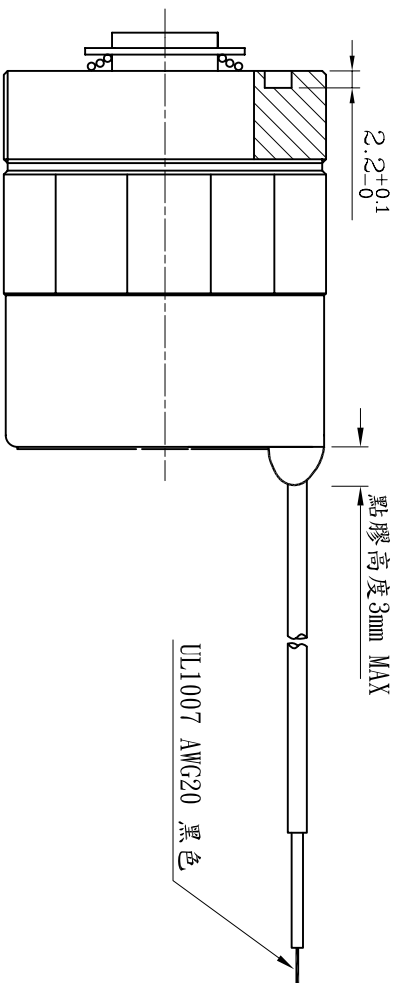
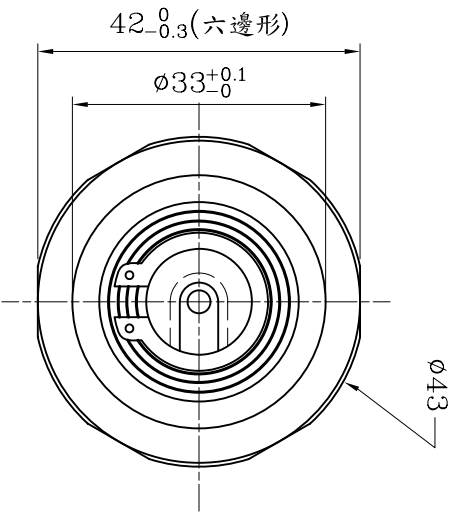

APPROVED	研發 JUN 19 2008 蔡春長	CONFIRMED	研發 JUN 18 2008 高尚謙	CHECKED	研發 MAY 22 2008 陳榮傑	DESIGNED	研發 MAY 22 2008 鄒志賢	DRAWN	研發 MAY 22 2008 鄒志賢
----------	--------------------------	-----------	--------------------------	---------	--------------------------	----------	--------------------------	-------	--------------------------

VER.	ECR08032101T	ENGINEERING CHANGE DESCRIPTION	鄒志賢	DATE
		料號統一及變更新圖框	20070508	

Unit: mm	Dimensions Tolerance	Material	
Scale: 1:1	0 ~ 3 ±0.2	Treatment	
Radius: R0.1	> 3 ~ 6 ±0.3	Finish	
Chamfer: 0.1*45°	> 6 ~ 30 ±0.5	DRAWING NO.	DWG 102-43A03
3rd Angle Projection	> 30 ~ 120 ±0.8	DRAWING NAME:	外形圖
General Machined Roughness	> 120 ~ 315 ±1.2	USED ON:	SMT-4349LXXAC
	> 315 ~ 1000 ±2	Page 1 of 1	VER. C
	> 1000 ~ 2000 ±3		